

Plans for making a Welding Table

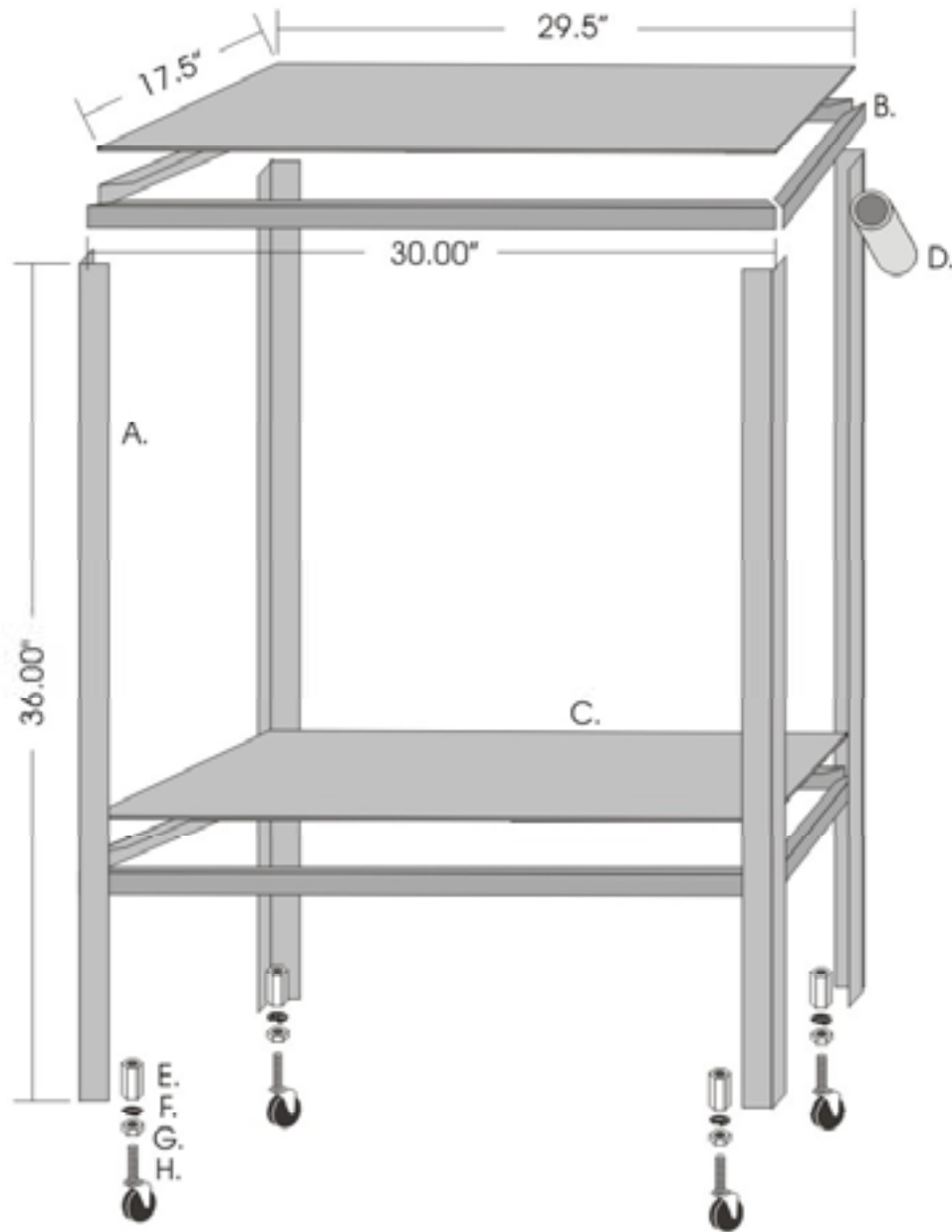

Materials List

Item:	Steel	Length	Quantity
A. Legs:	1/8"x1.25"x1.25" Angle Iron	36"	4
B. Frames	1/8"x1"x1" Angle Iron	48"	4
C. Work Surfaces	1/8"plate	17.5"x29.5"	2
D. Steel pipe	1.25 inside diam.	3"	1
E. Coupler nuts (found with threaded rod)			4
F. Lock washers			4
G. Standard nut to fit casters with threads			4
H. Casters with threads			4