

# KUNSTSTOFHASPEL

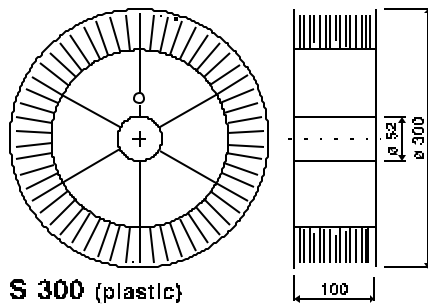

# KORFSPOEL

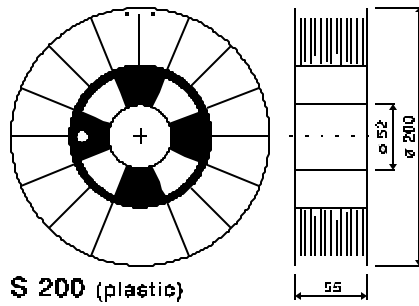

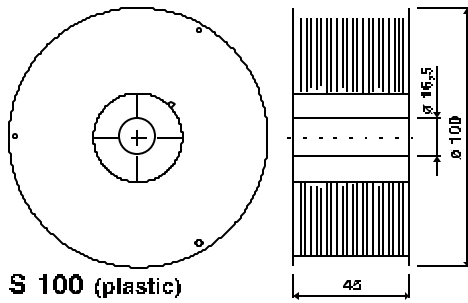
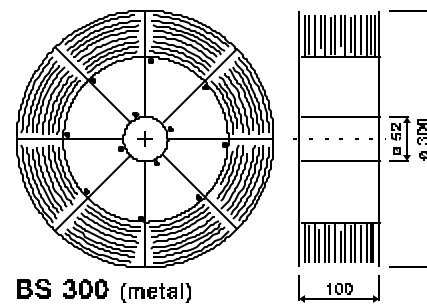
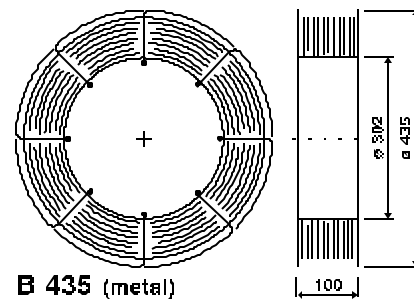
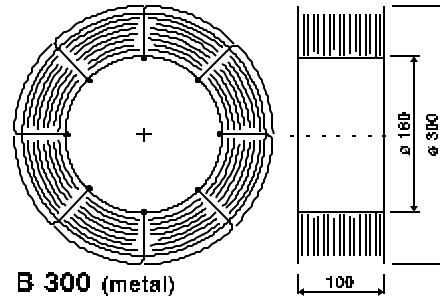
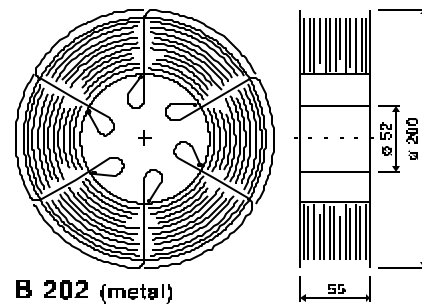
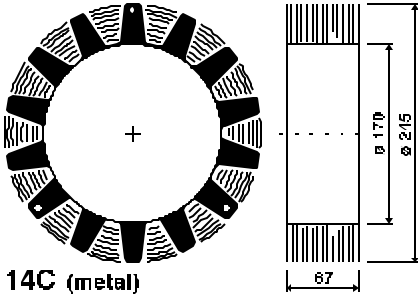

**14C (metal)**

**Adapter: K10075 (as 25 mm)**  
**Adapter: K435 (as 50 mm)**

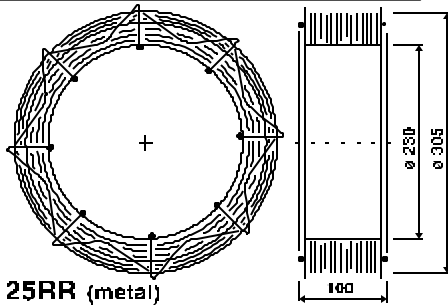

**25RR (metal)**

**Adapter: K363P**

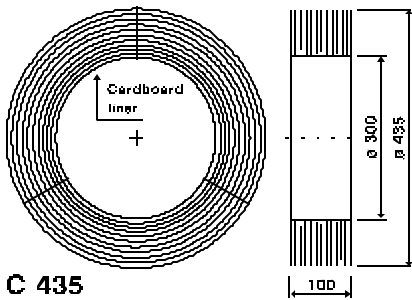

**C 435**

**Adapter: K10205-25 (as 25mm)**  
**Adapter: K438 (as 50 mm)**

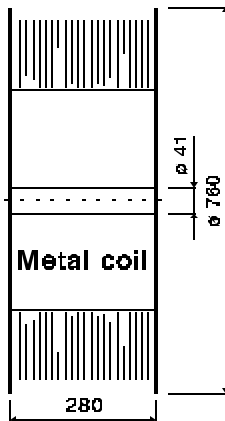

**Metal coil**

**50C**

**(metal)**

Binnendiameter 300 mm

Buitendia 420 mm

meter

Breedte 110 mm

**Adapter: K10075 (as 25 mm)**

**Adapter: K435 (as 50 mm)**

**22RR**

**(metal)**

Binnendiameter 230 mm

Buitendia 305 mm

meter

Breedte 96 mm

**Adapter: K363P**

**C400**

Binnendiameter 300 mm

Buitendia 400 mm

meter

Breedte 70 mm

**Adapter: K10205-25**

**C420**

Binnendiameter 300 mm

Buitendia 420 mm

meter

Breedte 85 mm

**Adapter: K10205-25**

**Afwikkelunit: DA 100/300Z**

of;

**Afwikkelunit: TR 100/300**

# AccuTrak



**NEW**

## **Afwikkelu**

**nit:**

**Hood:** K884-3

**Liner:** 1,8 mtr 2105120

2,1 mtr 2105121

2,7 mtr 2105122

6,9 mtr 2105180

9,3 mtr 2105181

## **Afmeting AccuTrak**

Diameter: Ø 510 mm

Hoogte: 800 mm

## **Voordelen:**

*G bruiksvriendelijk:*

Eenvoudig in gebruik

Geen adapters nodig

Geschikt voor alle lasapparatuur

*Hoge productiviteit*

Minimale wisseltijd

Eenvoudig te verwisselen

*Onderhoudsvriendelijk:*

Minimale slijtage van de onderdelen, dus minder onderhoud en kosten.

*Handling en opslag:*

Veilig.

Schone draad, geen stof en vervuiling vanaf de werkvloer.